



CYCLOPS

Instrument for studying:

- **Exoplanetary Science**
- **Metallicities & Abundances**
 - **Milky Way Formation**
 - **Asteroseismology**

at the AAT.



Overview

The CYCLOPS facility will significantly upgrade the Anglo-Australian Telescope's ability to carry out the high-profile task of detecting planets orbiting other stars, as well as providing significantly greater capabilities for a number of other compelling astronomical programs. It will do this by using optical fibres to reformat the light collected from the telescope's focal plane, and then feed it into the telescope's planet-finding spectrograph, in such a way that it collects 50% more light and records it with almost doubled spectral resolution.

The primary scientific driver for this new facility is the search for planets orbiting other stars. Australian astronomers, and the Anglo-Australian Telescope, have played a leading role in this new frontier for astronomy, detecting 25 of the 250-odd extrasolar planets known to orbit nearby stars. The CYCLOPS project brings together a team of leading Australian astronomers to build on this track record with a new facility that further advances Australia's capabilities in both this field, and several other high-profile astronomical endeavors: including the study of seismology in stellar interiors, the detailed measurement of elemental abundances in stars throughout our Galaxy, and the mapping of spot features on the surfaces of stars.



Science

Since the discovery of spectroscopy astronomers have been using spectrographs based around long and very thin slits. The slit in a spectrograph determines the spectral resolution - the finer the slit, the higher the resolution. Unfortunately, as a slit narrows we can admit less and less light from star images, which are essentially round.

CYCLOPS circumvents this limitation by magnifying a stellar image at the focus of the AAT in such a way that most of the light from a star image can be captured by 15 optical fibres arranged in a more or less circular pattern. These 15 fibres then snake their way down to the "UCLES" which is an older style high-resolution spectrograph. The fibres are rearranged side-by-side and magnified by more optics so that, as far as the UCLES is concerned, a narrow slit, or "fibre-slit", is formed. It is now of such a size that the UCLES can perform in its highest resolution mode but now with at least twice the light that would otherwise have been captured.

Subsystems

The Cyclops system is made up of primarily three physical subsystems:

- a) Auxiliary Cassegrain Input system
- b) UCLES Slit output system
- c) Fibre Cable system

Along with these physical systems there are electronic and software components to drive and control sub-systems together

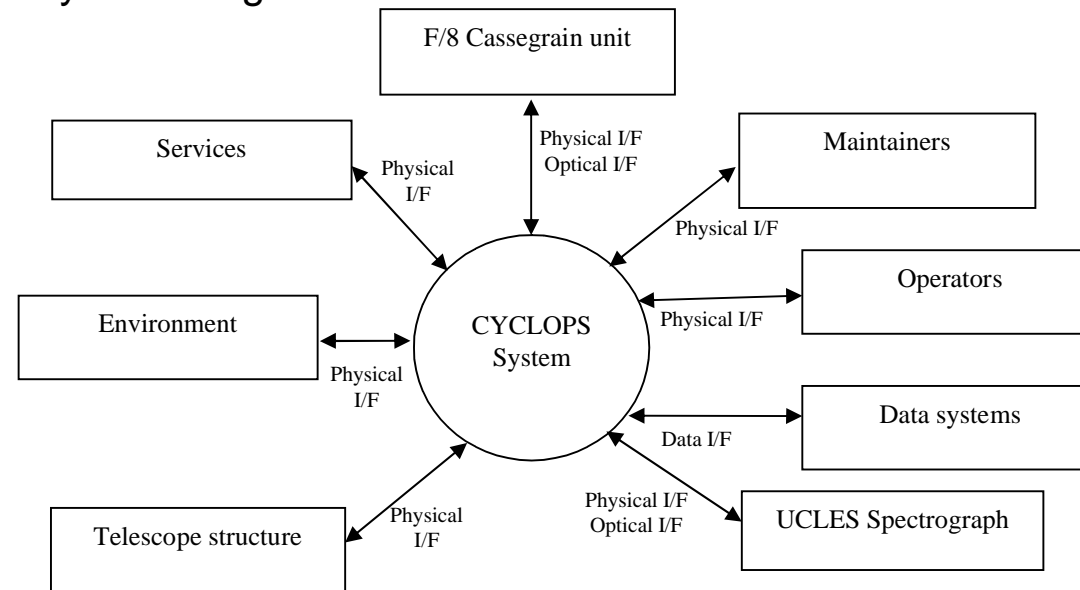

Subsystems

Auxiliary Cassegrain Input system

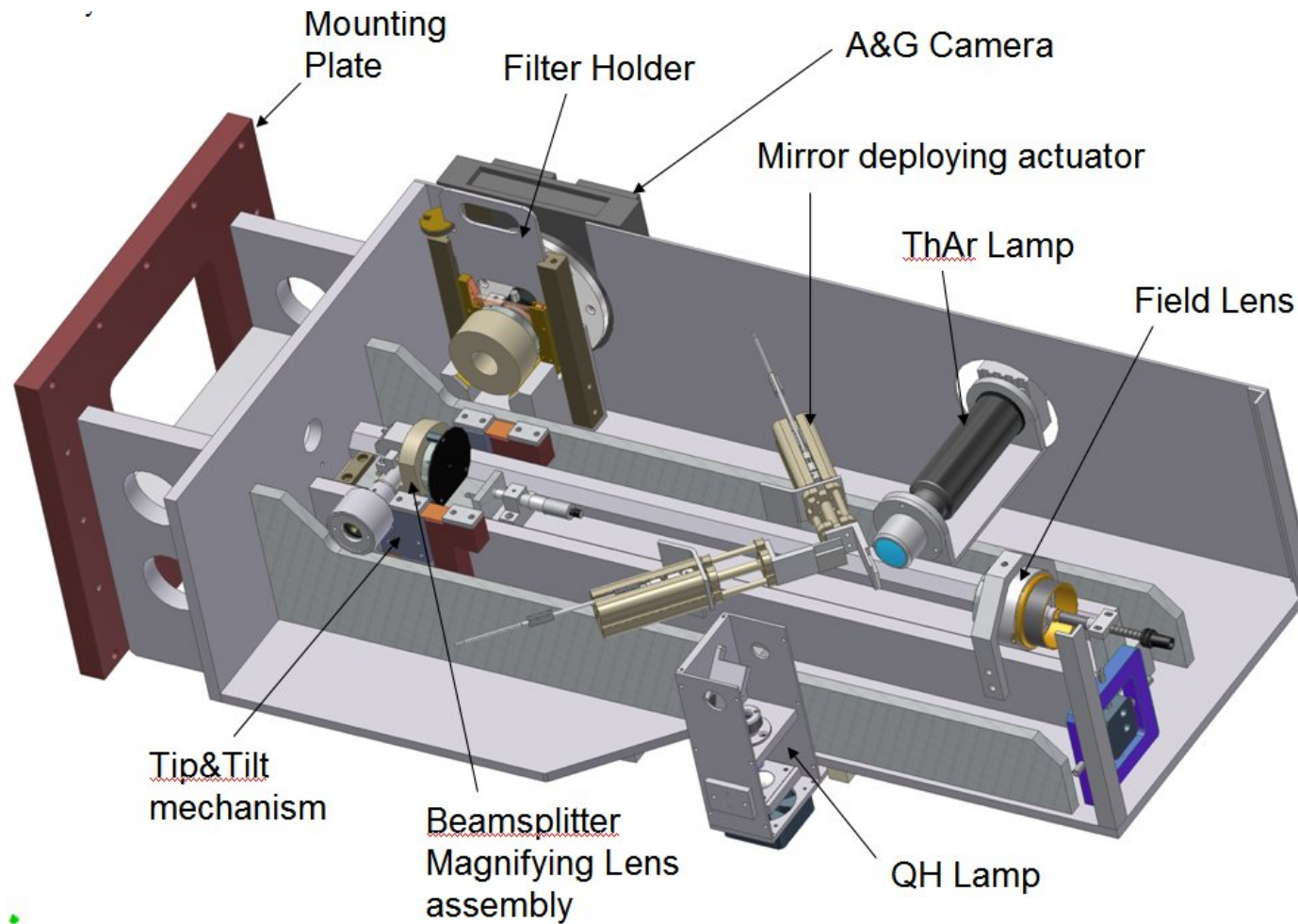

Subsystems

UCLES Slit output system

Relay optics

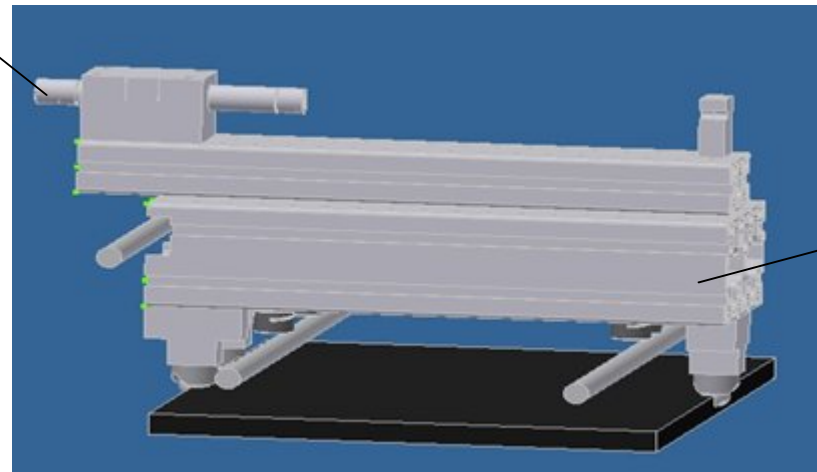

Kinematically supported structure

Subsystems

Fibre Cable system

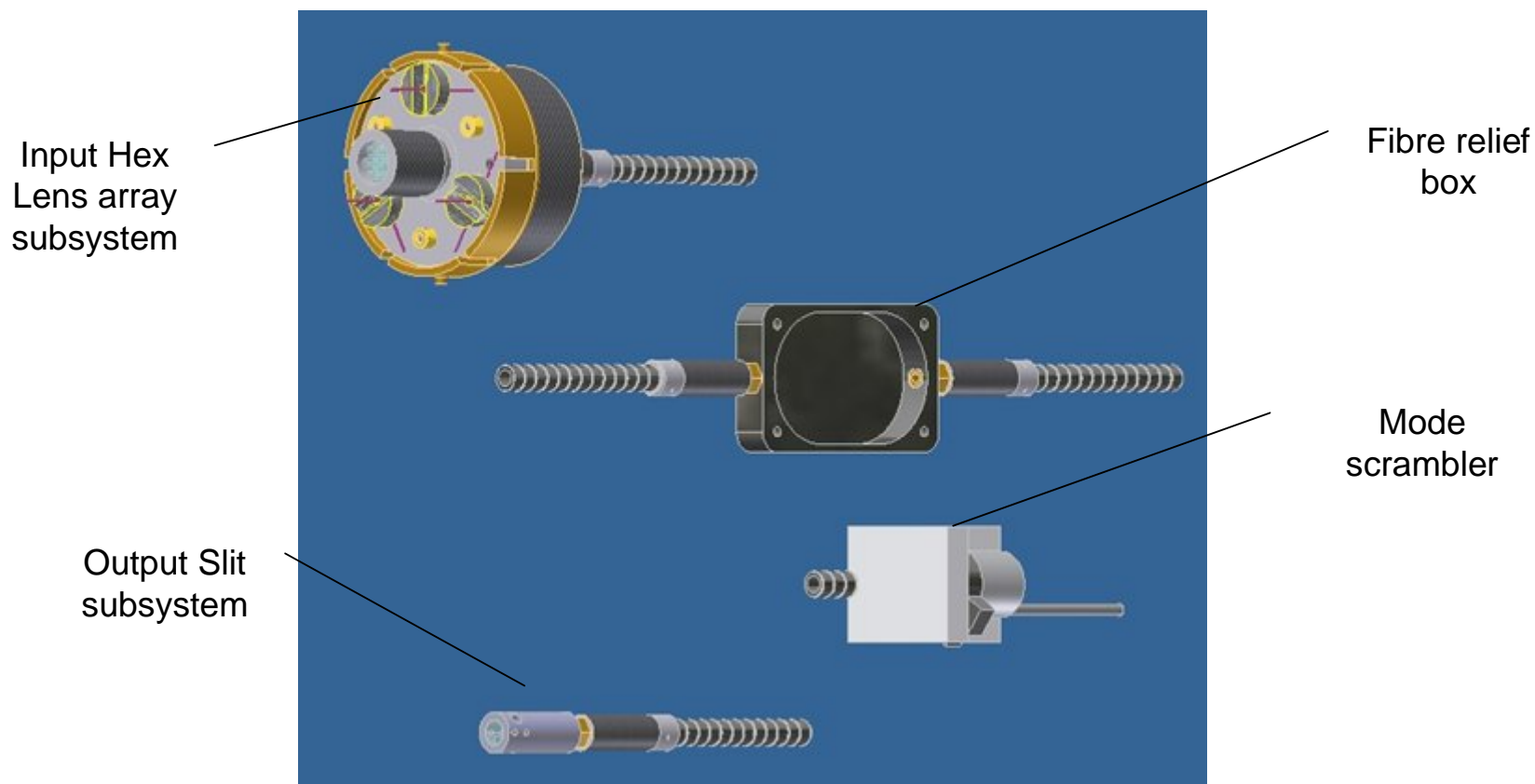

The Project

- Given:
 - Funds and resources provided by multi-institutions, including AAO, UNSW, USyd, ANU and Monash Uni
- Provide:
 - New IFU facility coupled to UCLES and Auxillary Cassegrain interfaces
- By:
 - Early of 2010
- Meet:
 - Science requirements

The Team

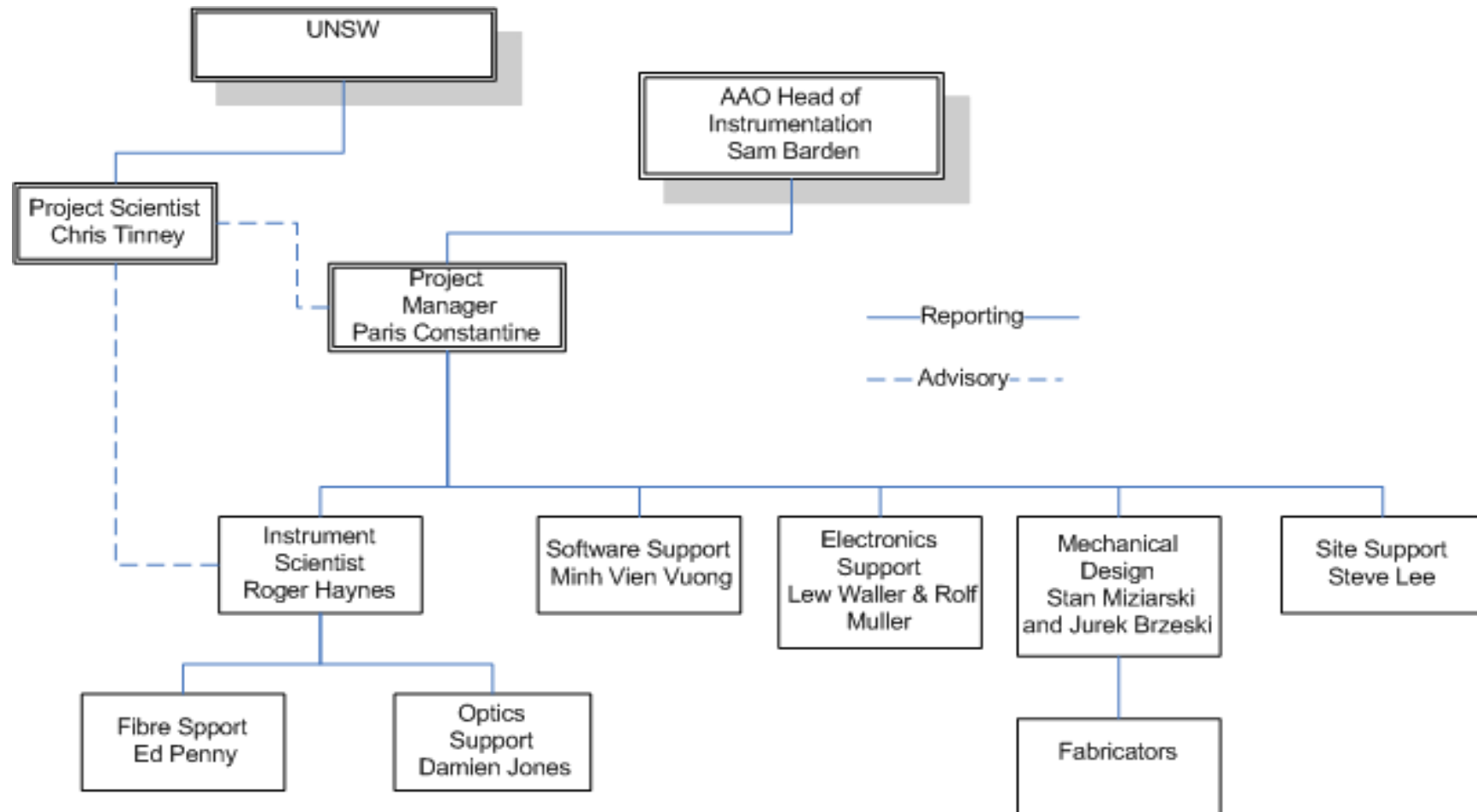

The Timeline

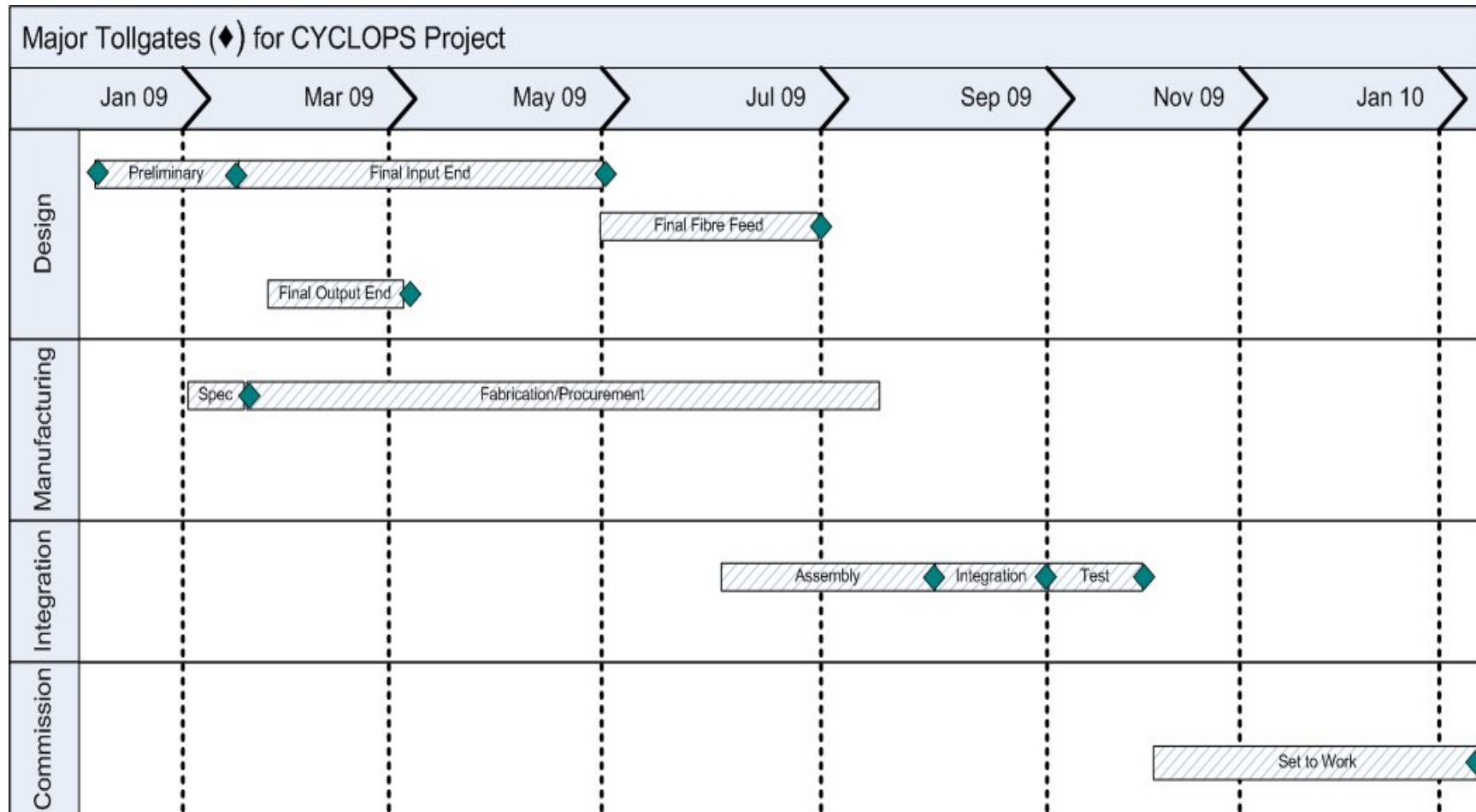

The Expectation and Measures of Success

- Provide a timely introduction of the facility
- Provide a professionally prepared design
- Provide innovative and world class solutions
- Maintain good relations and communications with site
- Remain customer focused
- Only be satisfied once the science has been achieved

Current Status June 2009

- Preliminary Design complete
- Critical Design complete
- Manufacturing and procurement processes commenced
- Commissioning Plan prepared
- FPRD and OCCD complete

Upcoming key dates and milestones

- Sep 09 for Assembly to commence
- Oct 09 for Subsystem testing to commence
- Nov 09 Telescope integration to commence
- Late Jan 09 Commissioning to commence
- Feb 010 Handover



Contact Details for further information

Project Manager – Cyclops
Paris Constantine
Email pc@aaogov.au

AAO
P.O. Box 296
Epping NSW 1710
Australia